

Waddington Electronics Inc.

General Catalog

03/21/08

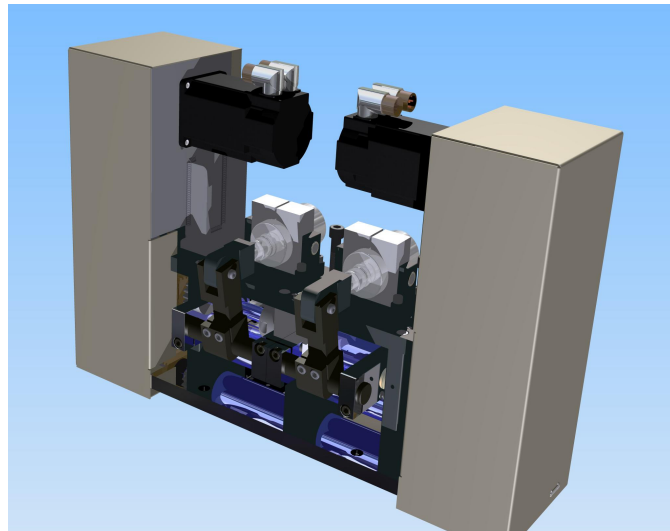

The Problem Solvers

Standard and Custom

- Programmable roll feeds
- Straighteners
- Loop Controls
- Tension Controls
- Mini Press

Roll Feeds

Wire and Tube Feeds

Dual Strip Feeds

Dual Drive Feeds

Zig-Zag Feeds

Feeds for Special Shapes

Push Pull Feeds

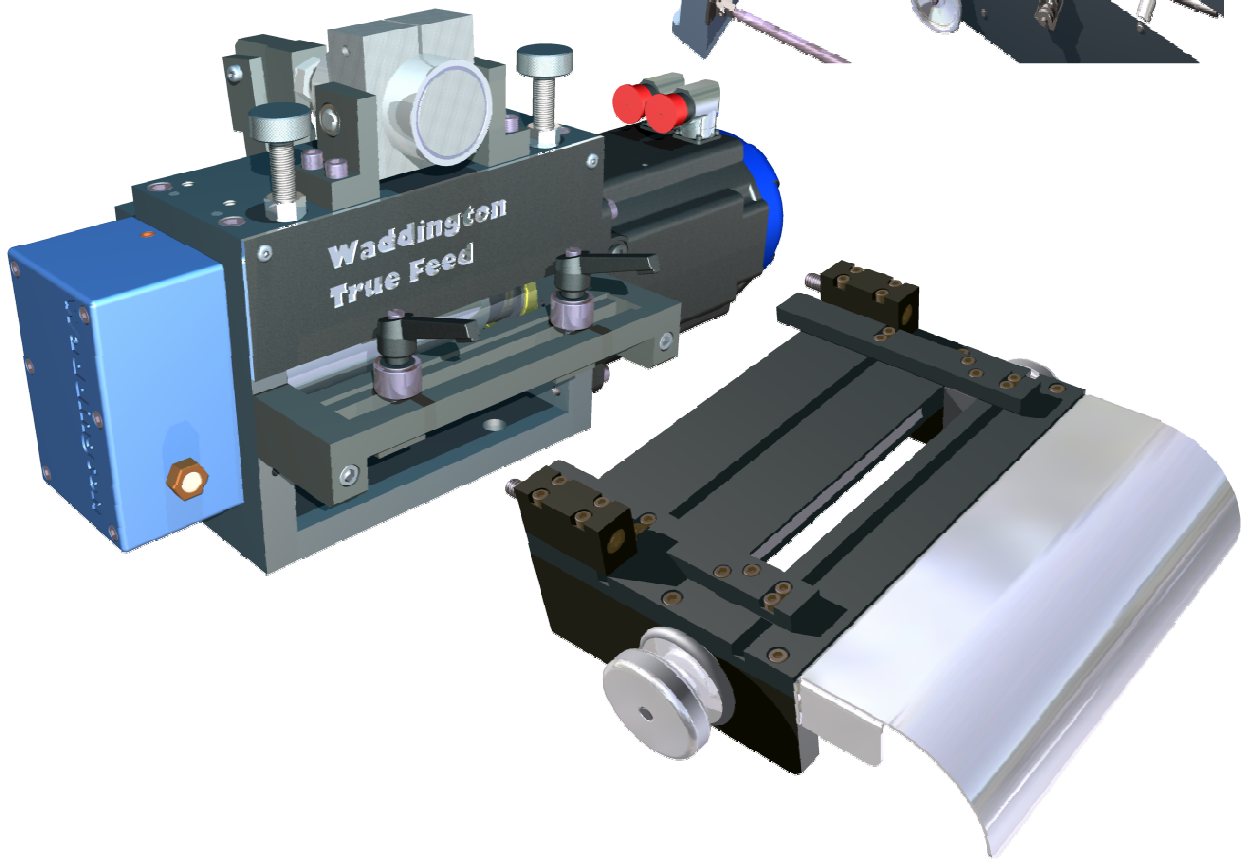
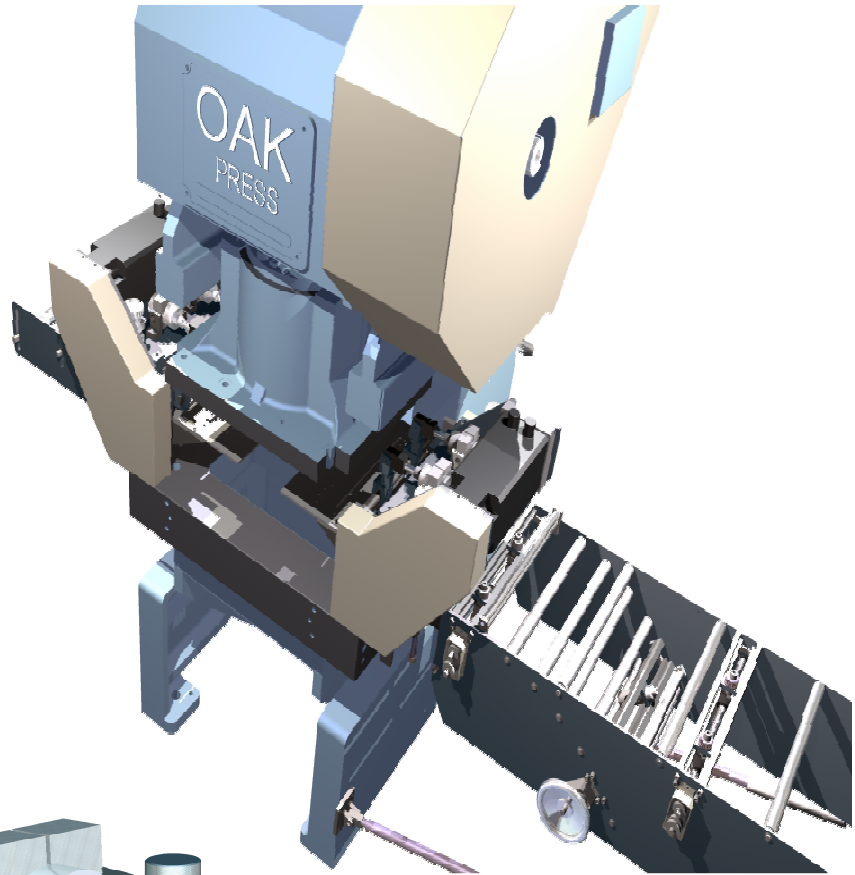

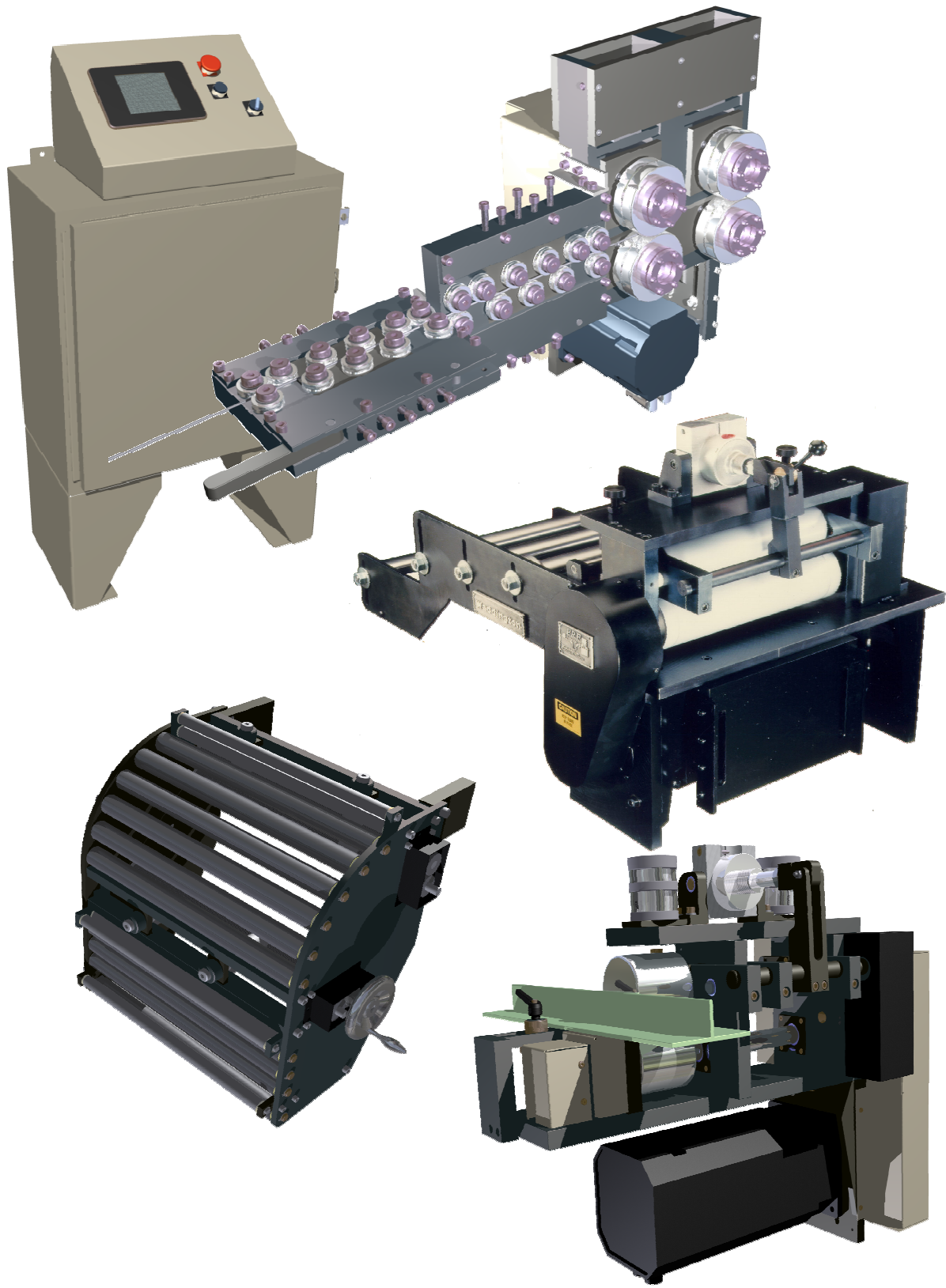

Stock Straighteners

5, 7, and 17 Straightening rolls

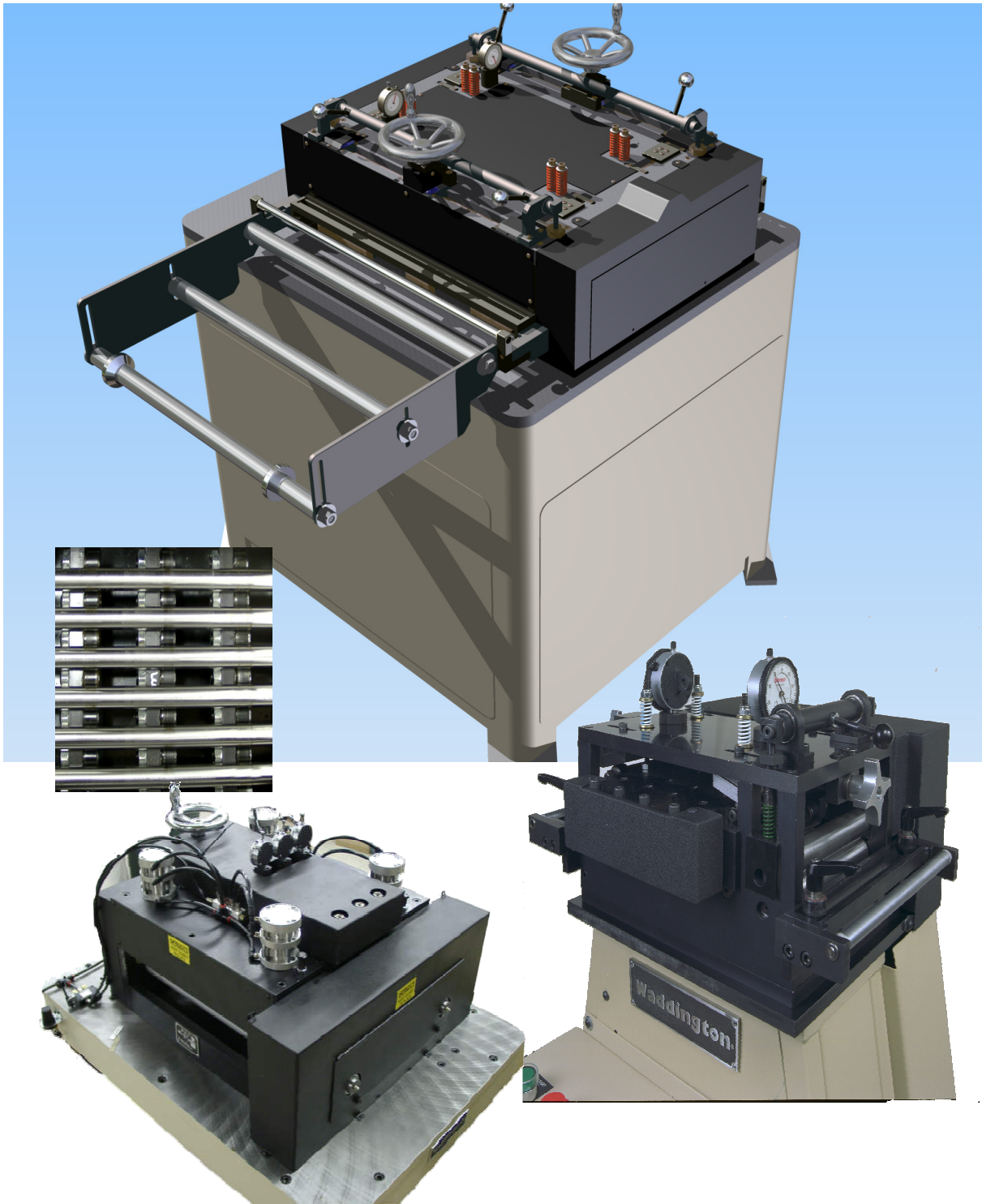

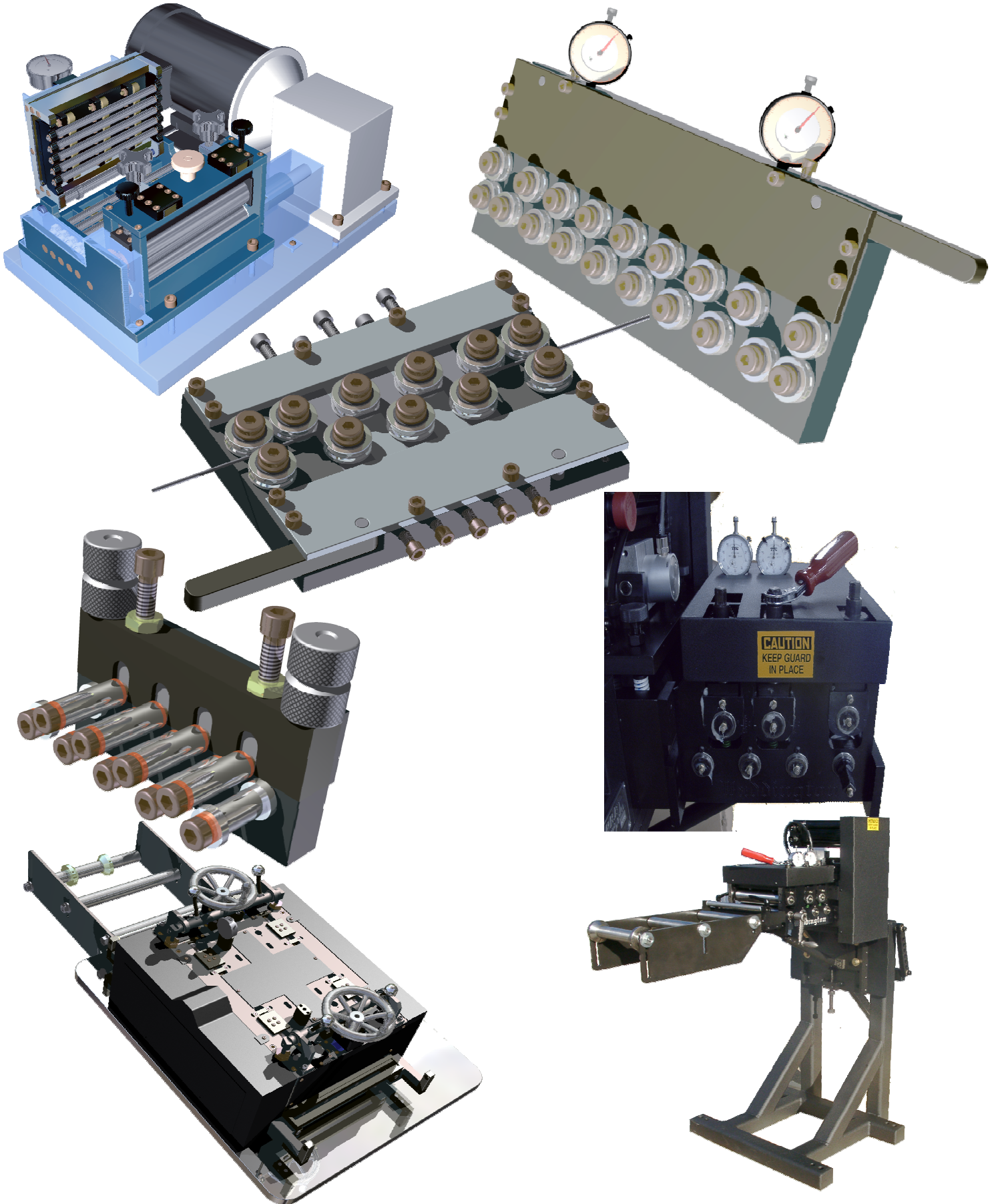

LOOP CONTROLS

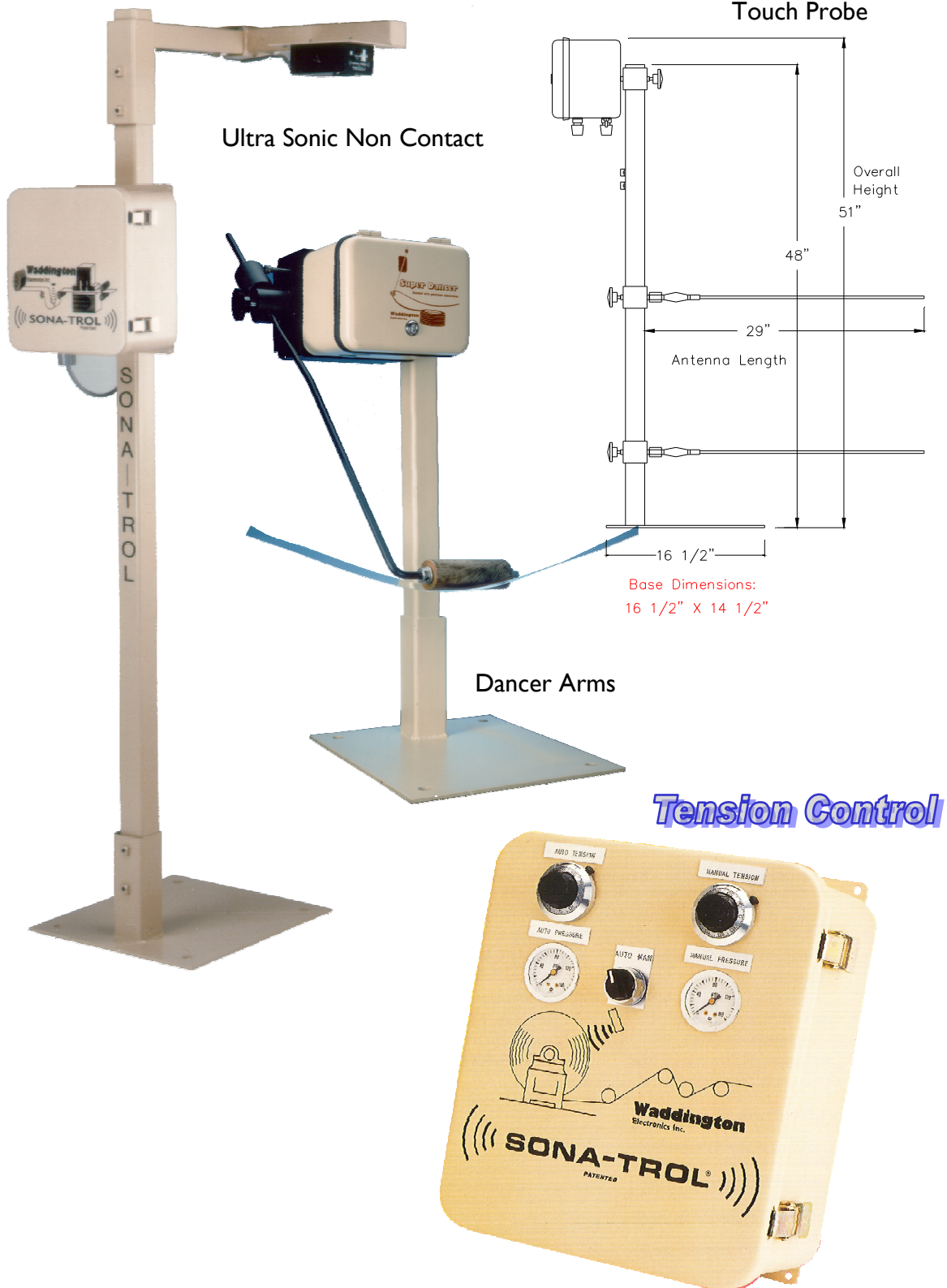

Loop Controls for all Industries

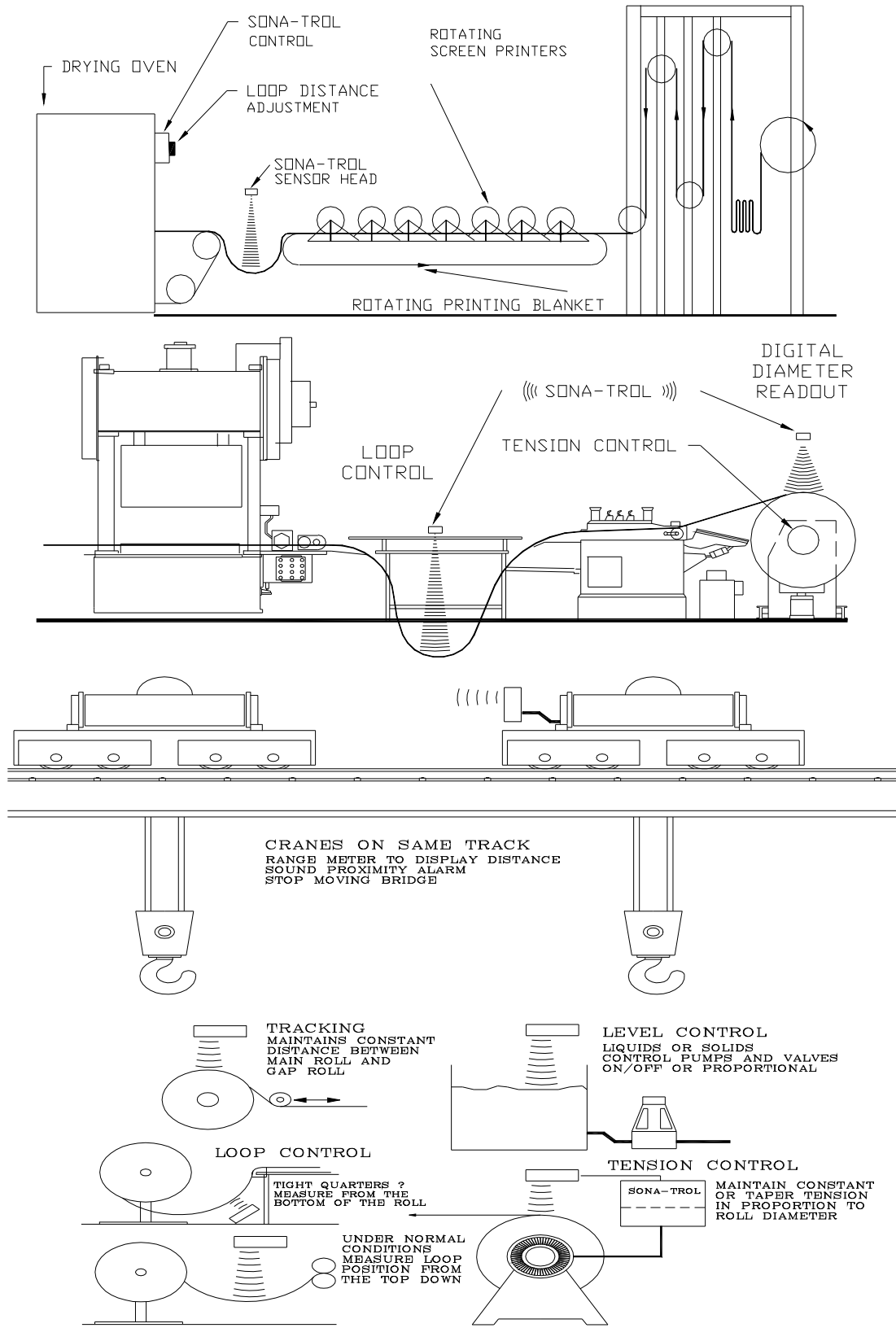

For application assistance call 1-401-781-3904

Mini Presses

Standard and Custom

Presses for Assembly

Stamping

and Cut-off applications

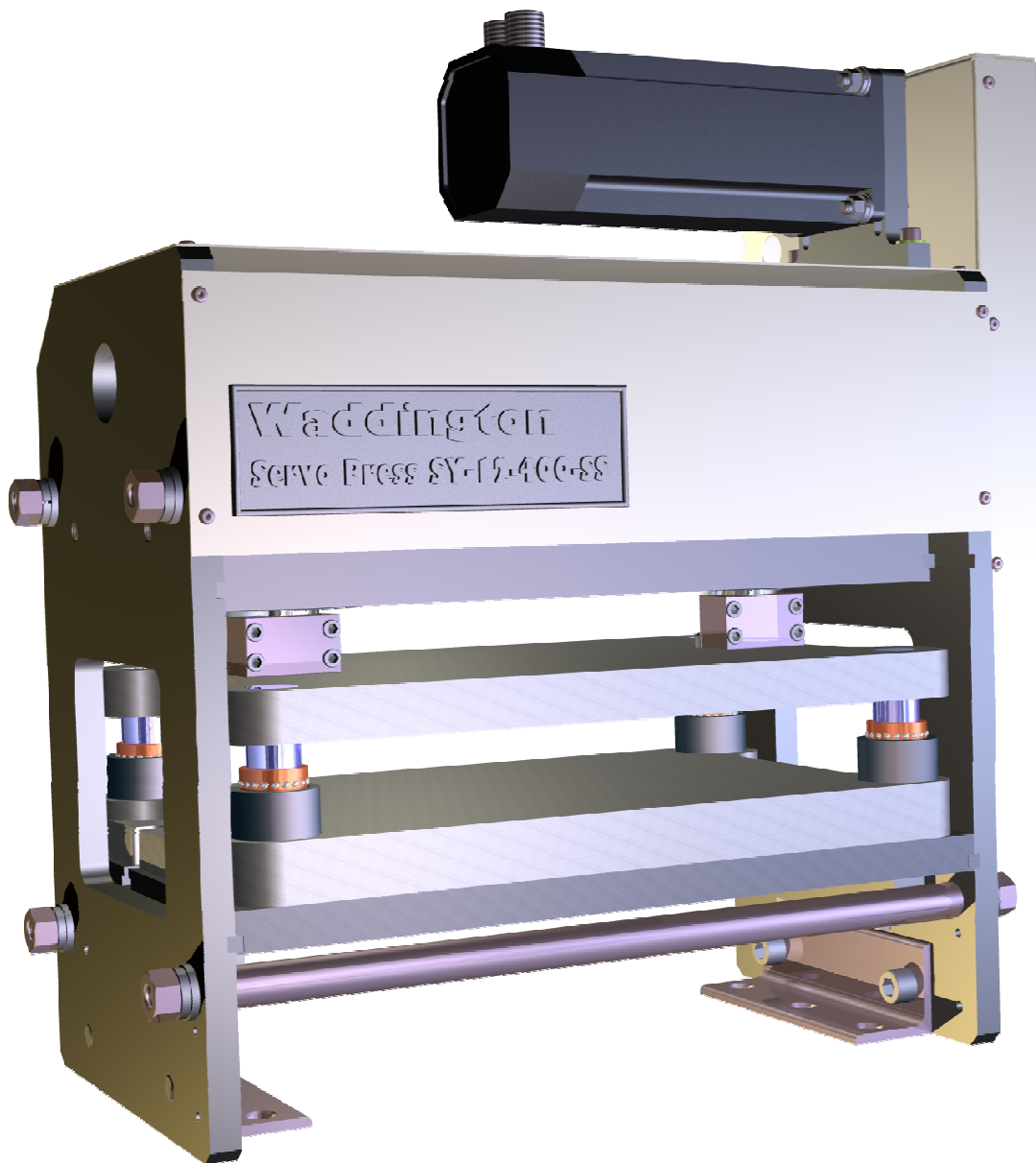

For application assistance call 1-401-781-3904

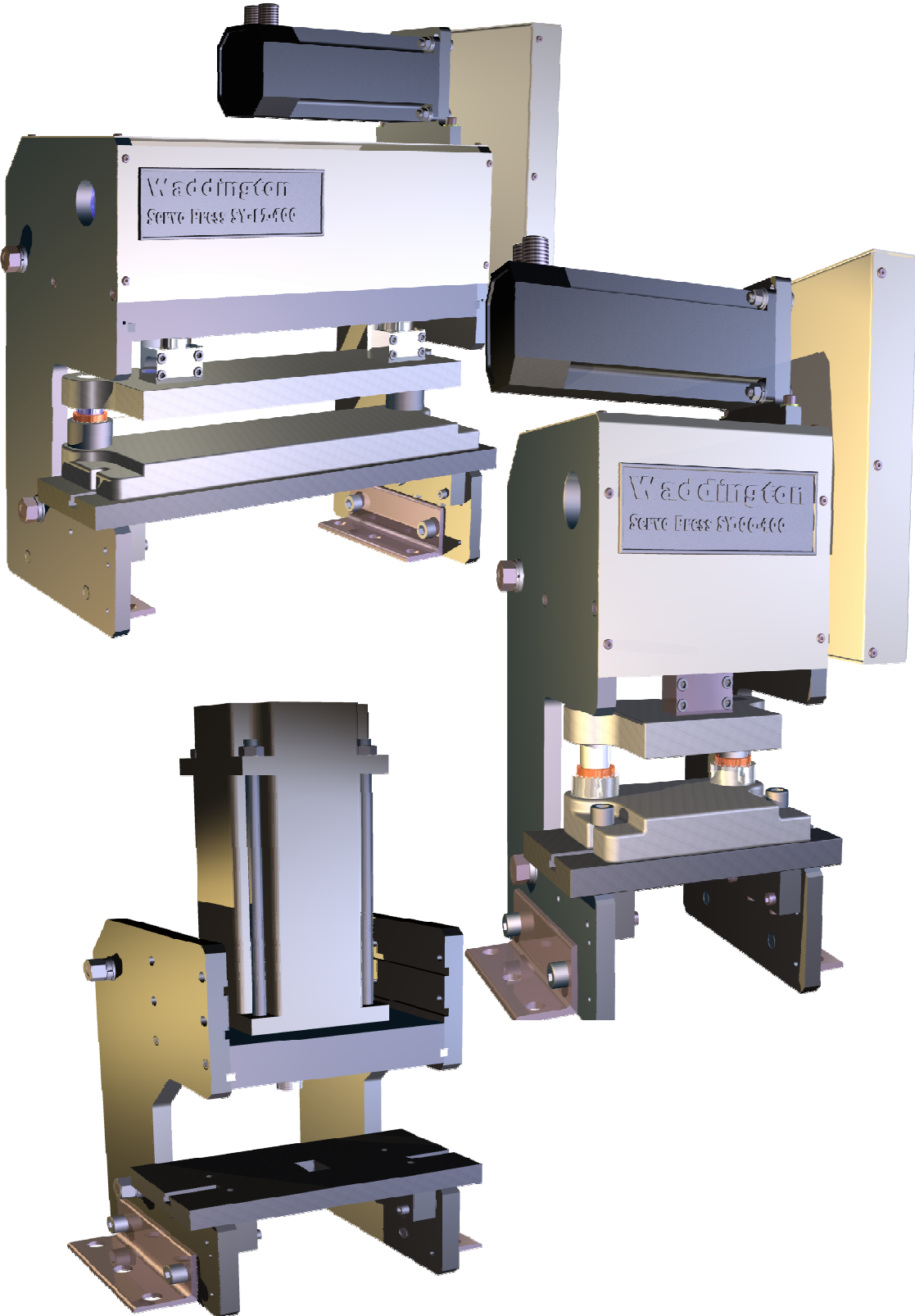

Dyna-Stop II

High performance DC Injection Brake for rapid controlled stopping of AC induction motors

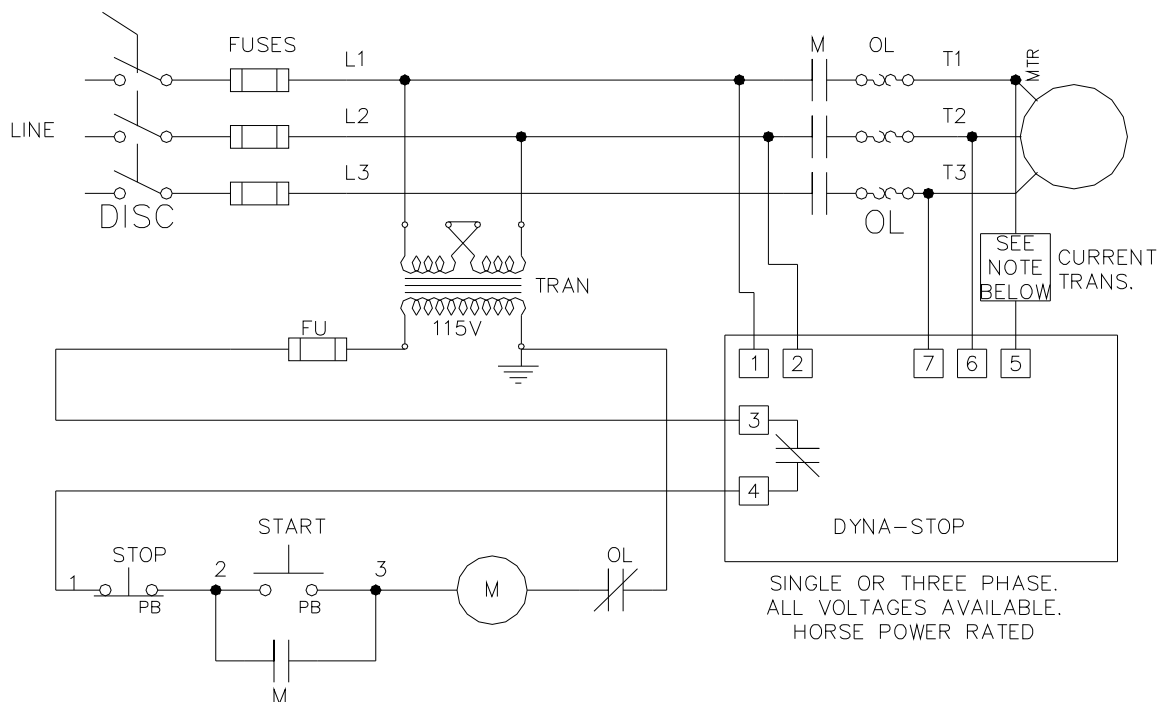
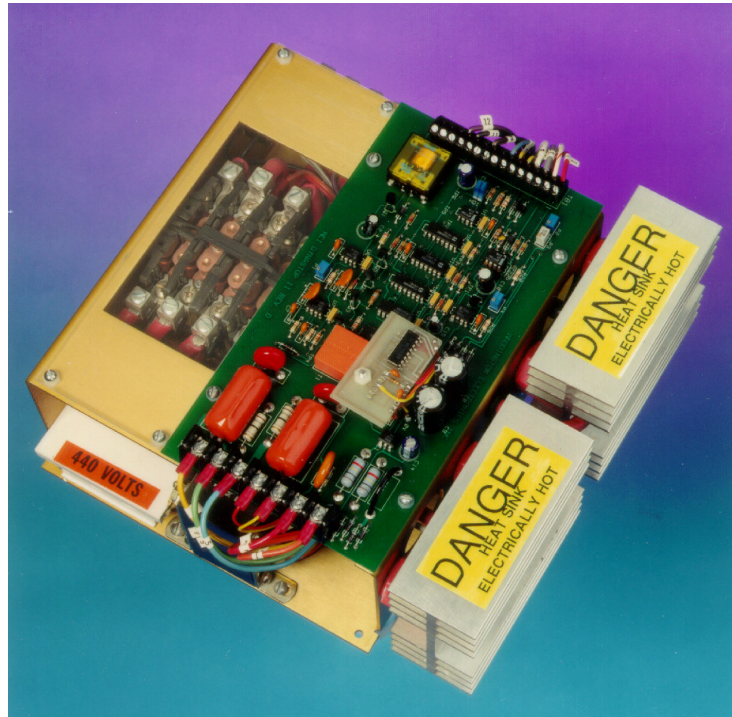

For application assistance call 1-401-781-3904



Power Supply	PS-3
Analog Signal Isolation Module	SIGISO-1
Master Reference Module	MASREF-1
PID Output	PID-2
RMS Output	RMS-2
Analog Divider (Constant Line Speed Calculator)	DIV-1
Voltage To Freq Output	V/F-1
Frequency To Voltage Converter	F/V-1
Analog Multiplier	MUX-2
3 Input Summing Amplifier	SUM3-1
% Ratio Option	%TAP-2
Voltage To Current Loop Converter	MAO-10 or 20
Voltage Comparator With Relay Output	LB-2
Differentiator / Summer Filter	DIFF-1
Load Cell Amplifier	LOAD-1
Pulse Width To Voltage Converter	PWVOLT-1
Pulse Width To Voltage Converter (Hi-Res)	PWVOLT-1/Hi-Res
Pulse Width Alarm w/Relay Output	PWALARM-2
Pulse Width Alarm (Hi-Res)	PWALARM-2/Hi-Res
Sonar Sensor	SSI
Triple Output Power Supply For SONAR	PWSUPPLY-1 to 4
Triple Output Power Supply For SONAR (Hi-Res)	PWSUPPLY-1/Hi-Res



Waddington Electronics Inc.

25 Webb St
Cranston RI
02920

Cranston RI USA
02920

Phone: 401-781-3904
Fax: 401-781-1650
Email: sales@waddingtonelectronics.com