

# Waddington Electronics Inc.

---

## Straightener

03/01/07

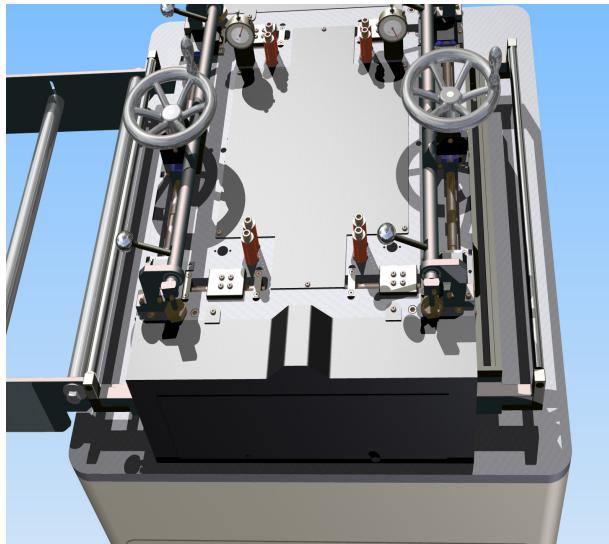

## The Problem Solvers

---

### Standard and Custom

- Production straighteners for coil and parts
- 21 roll precision straighteners
- Pull thru straighteners
- High speed Straighteners
- Straighteners for very thin material

### **A word about precision**

Some of the benefits of precision build equipment include:

- Longer tooling life
- Higher quality parts
- Improved profit margins.

Precision equipment allows faster setups

Repeatability and stability of setup and allows trouble free stamping runs from beginning to end of the production cycle.

### **About Us**

Waddington Electronics has delivered industrial control systems and, specifically, computer-driven Servo systems to the machine tool and metal stamping industries for over 50 years.

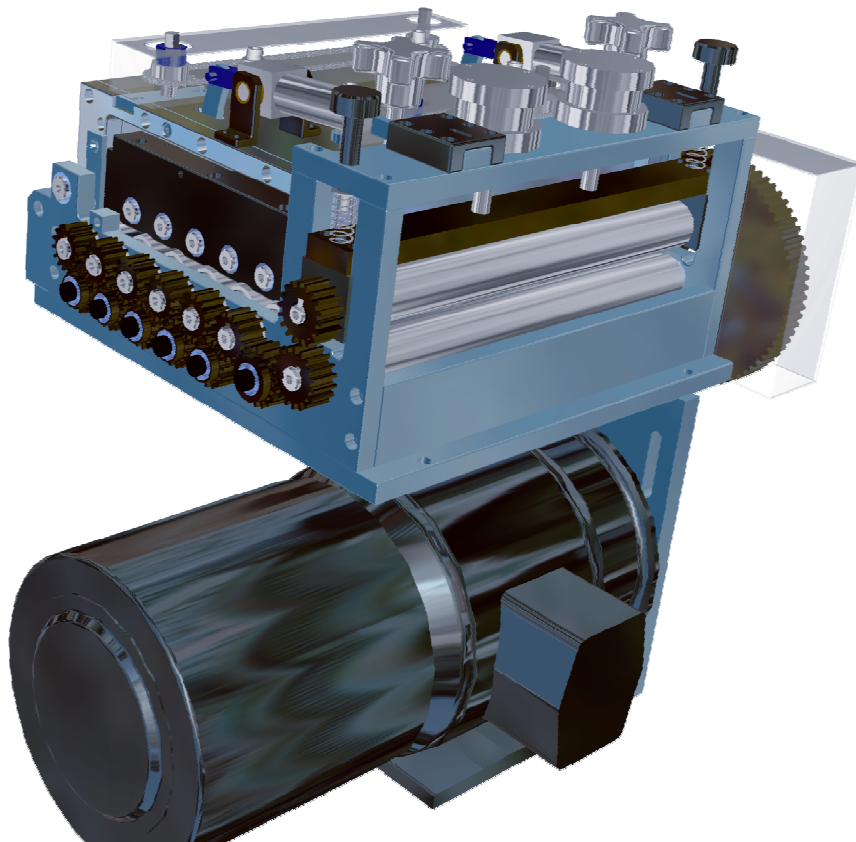

## Proven Performers

### **Precision Stock Straighteners**

The large numbers of straightening rolls allow a gentler, gradual straightening of the material and the unified upper roll bed design allows for easy setup and adjustment of the straightening process.

All straightening rolls are backed up to minimize roll deflection this allows the material to be heavily worked without imparting distortion into the length and width of the material.

Straighteners are equipped with 21 1.25 or 2-inch diameter rolls.

Electrical controls include high performance AC drives and non-contact ultrasonic loop controls. The drive system is designed to provide a smooth continuous flow of material to the feeder. And eliminates material dragging across the floor.

When combined with today's high-speed presses and feeders the superior features of the PSS Straighteners allow higher levels of production, quality, die life and profitability.

Standard Features Include:

- AC Vector Drive Package; including:
- SONA-TROL control and start/stop/jog forward/ jog · reverse/auto/manual selector switch and remote push buttons for jogging on a coil cord in a NEMA 12 enclosure
- Dial indicators
- Continuous running with no set marks
- One piece hardened and ground rolls (.0002 TIR) positively powered and backed up
- Three-inch entrance and two inch exit powered pinch rolls
- Controls include forward / reverse and remote jog
- Hardened drive gears
- Ground heavy duty side plates and bearing blocks
- Rugged steel machine base with ground top

## Improve your bottom line with the PSS Series

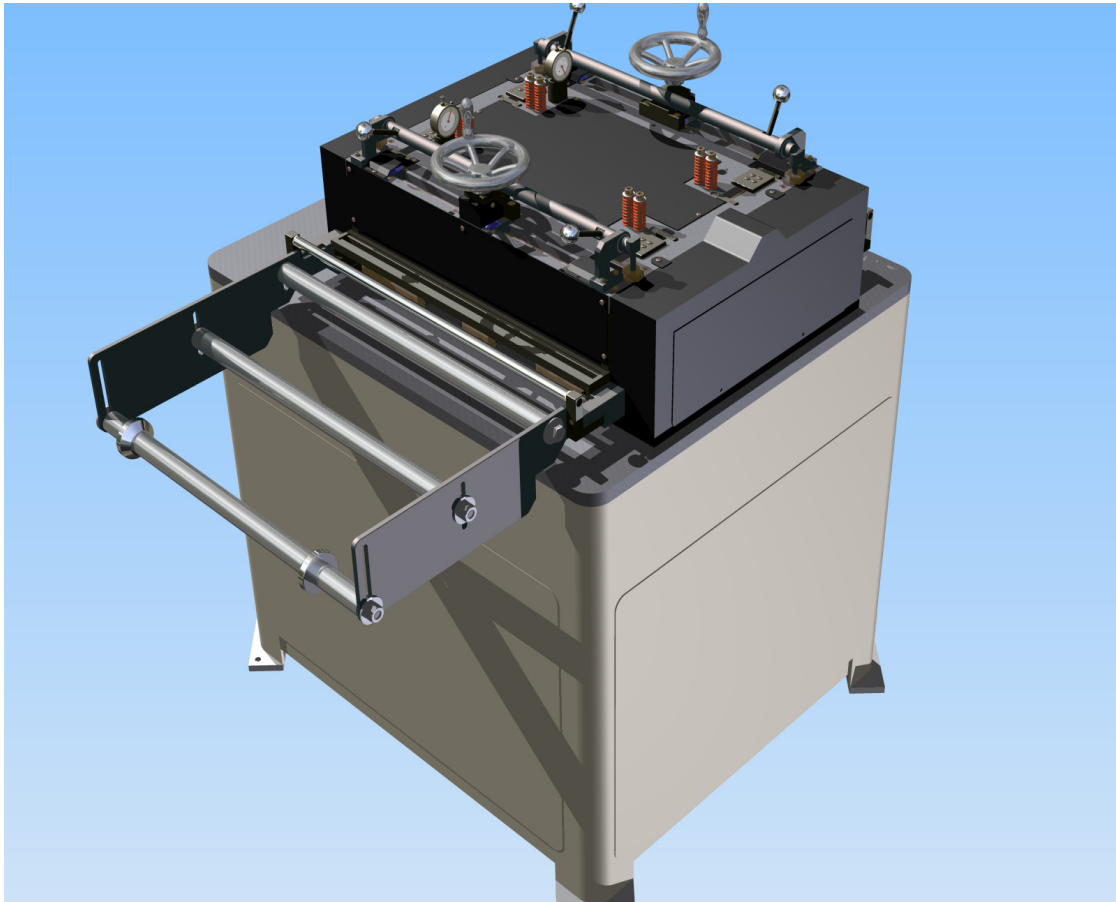

Waddington Precision Stock Straighteners feature modern design and components.

They are built to exacting standards. All machines are designed and built with attention to detail, and every machine is thoroughly tested and inspected before shipping

Precision ground components made from stress relieved steel insure precise alignment allowing you to work the material beyond its yield point without imparting distortion into the strip because of machine deflection.

- High speed precision straightening
- Stress relieves material
- Great for motor and transformer laminations
- All rolls driven
- Easy bank adjustment
- all rolls backed up
- 1.25 and 2" diameter rolls
- 3" pinch rolls
- coil and parts straightening

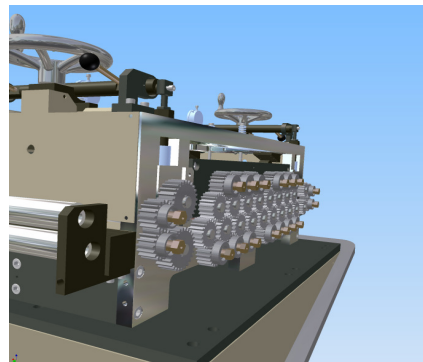

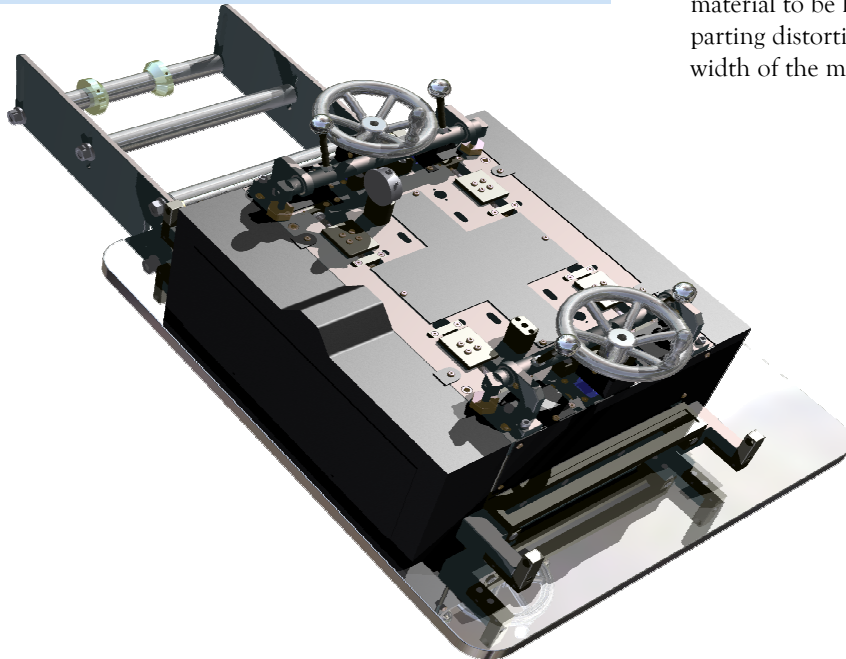
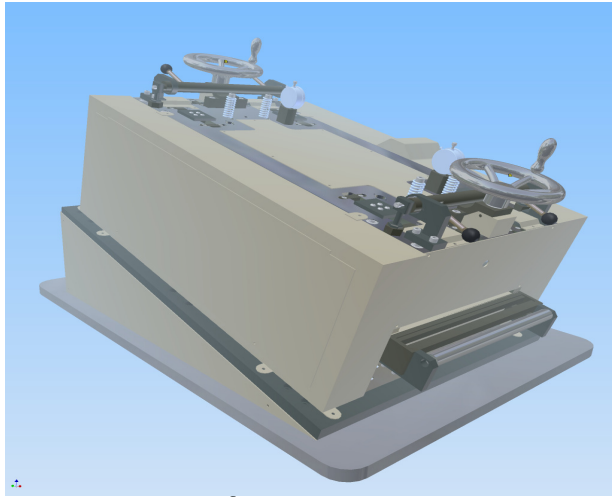
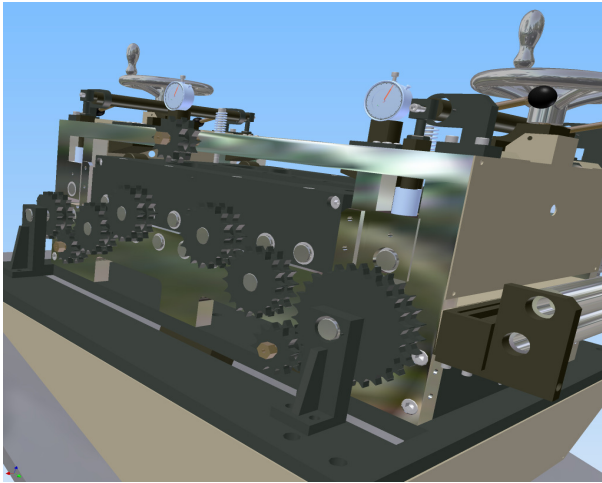

Designed to complement today's high speed Servo driven roll feeds, Waddington PSS high performance Precision Stock Straighteners deliver easy setup and superior straightening capabilities.

Setup is fast, easy, accurate, and repeatable. Upper roll bank adjustments are made simply by turning hand wheels located at the entry and exit sides of the machine. Dial indicators allow precise settings to be accurately repeated so that valuable time is not wasted with trial and error adjustments associated with lesser equipment.

With its 21 rolls this straightener eliminates problems associated with coil set variation from the start to the end of the coil or changes occurring when switching from running off the top or bottom of the coil. This precision stock straightening machine will deliver flat stock to your feeder faster and flatter than any 5, 7, 11, or 17, roll machine on the market.

The large numbers of straightening rolls allow a gentler, gradual straightening of the material and the unified upper roll bed design allows for easy setup and adjustment of the straightening process.

All straightening rolls are backed up to minimize roll deflection this allows the material to be heavily worked without imparting distortion into the length and width of the material.

---

To Order Call: 1-401-781-3904



### VTSS

- For very thin material
- 5/8" diameter rolls
- 3 sets of backups
- 17 Straightening rolls
- All rolls driven
- Sealed ball bearings
- Grease or oil will not contaminate material
- Easy setup bank adjustment
- Dial indicators
- Machines available from 6 to 12 inches wide

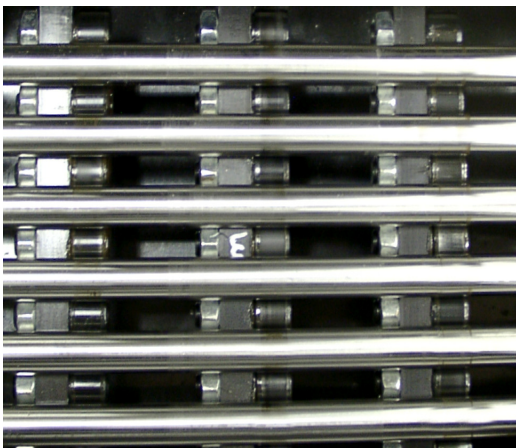
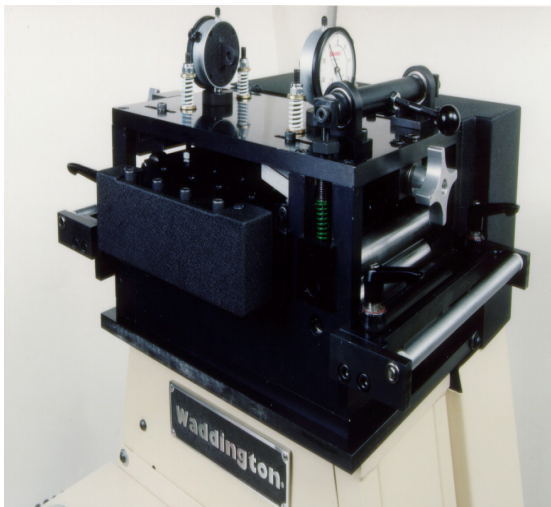

The Waddington VTSS-19 coil straightener features 19 fully powered rolls including 17 for straightening and 2 pinch rolls, With a unified top roller bed assembly that holds the upper straightening rolls in a single plane to provide progressive leveling action. Employing 5/8" diameter one piece hardened and ground rolls, It Handles stock from .003 thick and up to .035" thick at the maximum 12" stock width.

Capable of up to 1800 in/min operation, the Waddington VTSS-19 Coil Straightener is compatible with servo driven roll feeds and incorporates a 3/4 HP DC regen drive package Including SONA-TROL Ultrasonic loop controls with forward, reverse, and remote jog. Dial indicators are provided to facilitate adjustments and all rolls are backed up ( 3banks for a total of 57 rollers ). Parts straightener also available

---

To Order Call: 1-401-781-3904

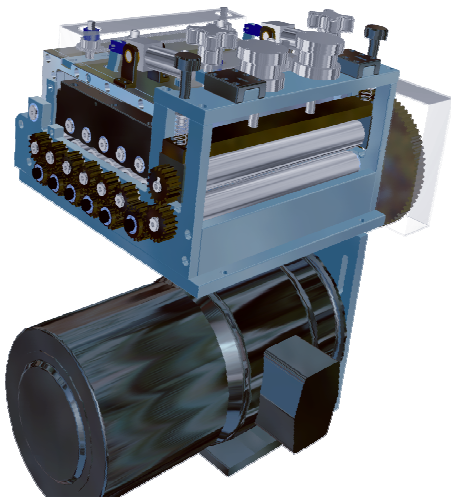

### **Precision Flip Top Stock Straighteners**

Waddington Flip Top Stock Straighteners...

Feature modern design and components

· Built to exacting standards

Crafted from precision ground components  
made from stress relieved  
steel.

Our backed up roller beds

Allows for working

the material

beyond its yield

point without

imparting distortion

into the strip

because of roll deflection.

Available in 3/8, 7/8, and

1.25" diameter roll machines

in widths from 6 to 18 inches

Dial Indicators provide for exact

and repeatable settings for Fast Setups

and reliable results

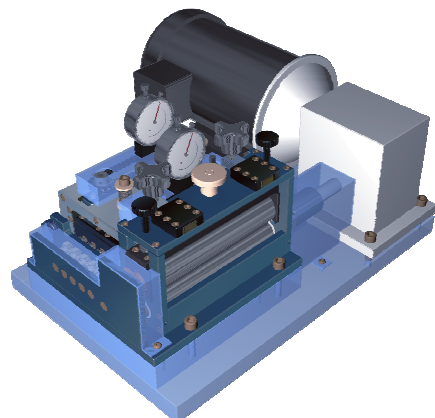
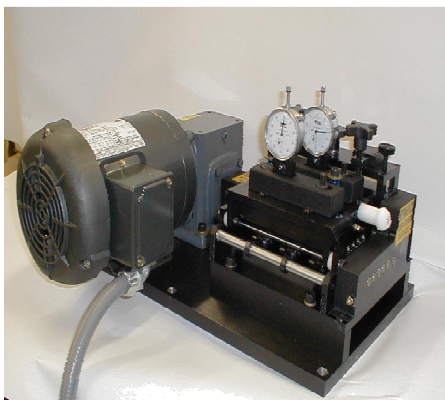
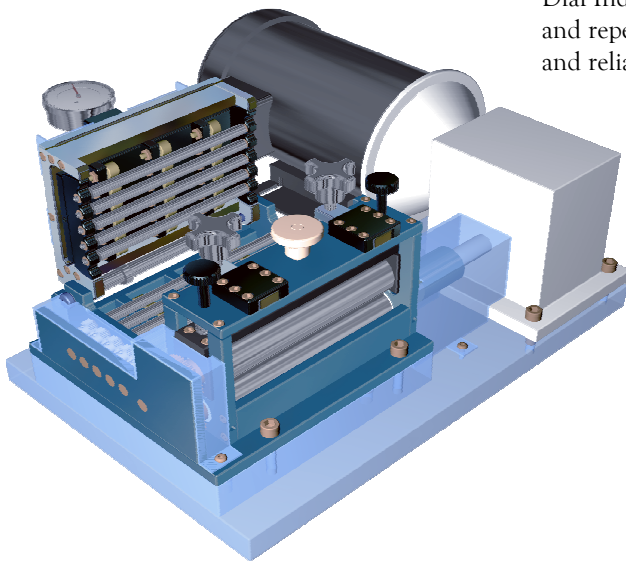

---

To Order Call: 1-401-781-3904



### General purpose straightening machines

- Machines from 6–36 " wide
- 11 rolls
- 7 straightening rolls
- 2 entry and exit pinch rolls
- Quick release pinch rolls for easy threading
- Adjustable pinch roll pressure
- 3 Dial indicators
- Two or three diameter rolls
- 2.5 or 3.5" roll spacing
- Heavy duty 7 roll straightener
- All rolls hardened and ground
- Anti-friction bearings on all rolls.
- AC vector drive package; including:
- SONA-TROL control
- Auto/manual selector switch
- Remote push buttons for jogging on a coil cord
- 175 ft / minute max operating speed
- All machines structural parts are ground flat ground before machining.
- Ground heavy duty side plates and bearing blocks
- Rugged steel machine base with ground top

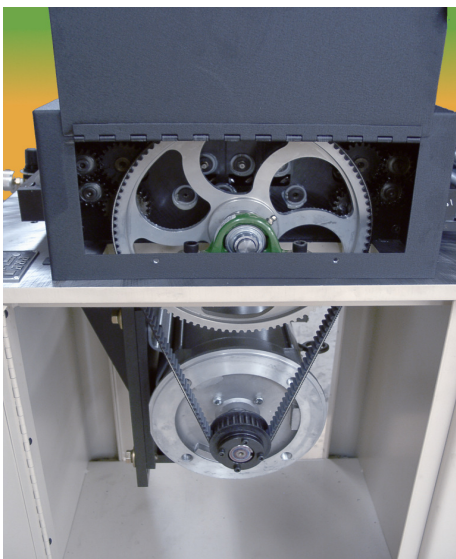
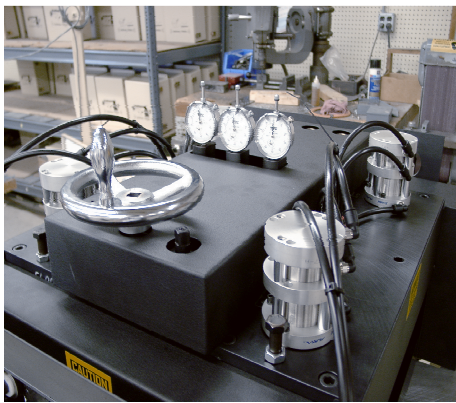





### Controls

SONA-TROL control with start/stop/jog forward/jog reverse/auto/manual selector switch and remote push buttons for jogging on a coil cord in a NEMA 12 enclosure.

Also available

Super Dancer, Photo-Trol, Probe-Trol

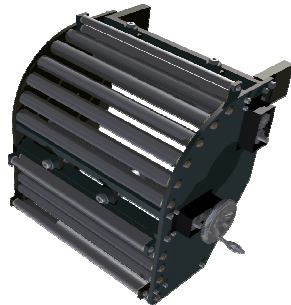

### Entry and Exit options

Cascade rolls

Special guides

Parts catchers

Stock bridges

All designed to suite your application.

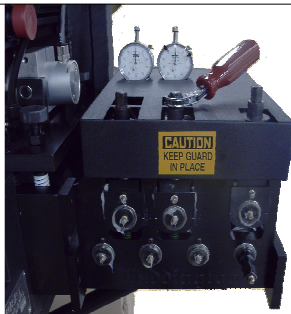

### Small Pull Through Straighteners

The finest pull through straightener you can buy. Designed to be used with servo feeds where precision and accuracy are required for proper operation

- Rolls are 1 piece hardened, ground (.0002 tir) and flash chromed
- 1" thick steel side plates
- Precision ground and machined
- Includes entry pinch rolls for easy threading
- Engraved roll height scales or dial
- Indicators
- Available from 6 to 24 inches wide

To Order Call: 1-401-781-3904



### **Large Pull Through Straighteners**

Available from 24 to 48 Inches wide.  
5 or 7 rolls at either 2 or 3 inches in  
diameter.

Air operated entry pinch rolls with Anti-  
backup feature for easy threading.  
All rolls are backed up to minimize  
deflection.

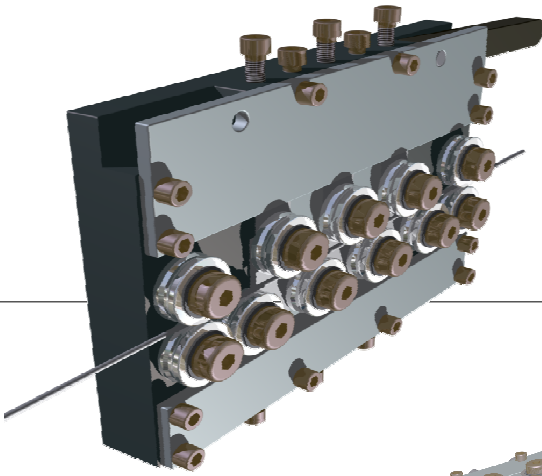

### **Wire Straighteners**

With quick release for easy threading.  
1, 2, or 3 plane straightening

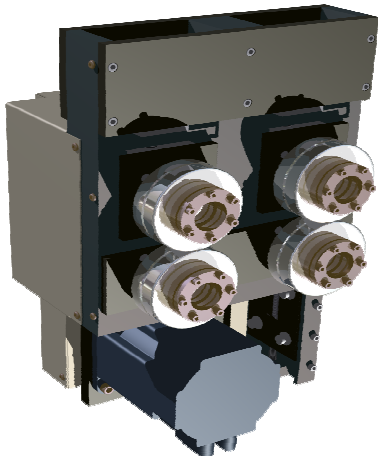
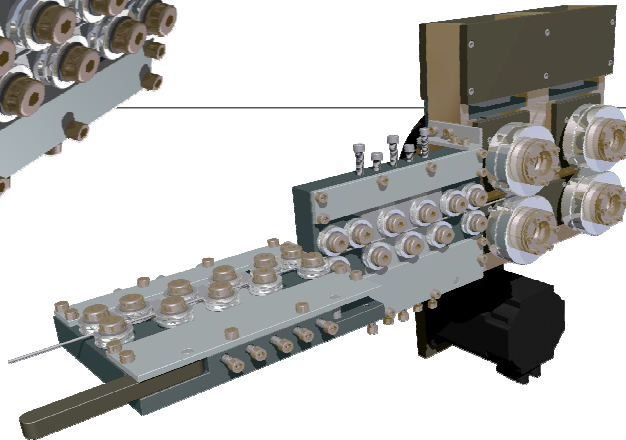

### **Wire Feeds**

Servo Driven

---

To Order Call: 1-401-781-3904

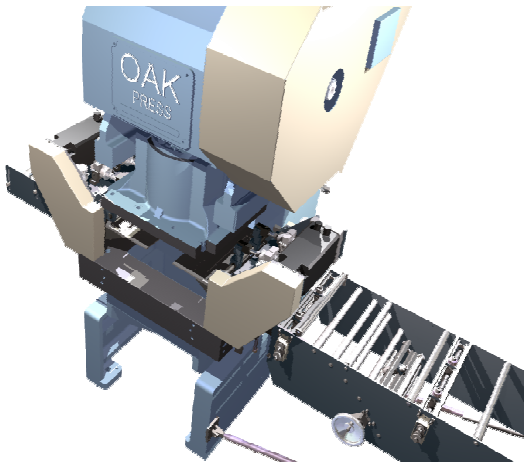

**See Our Other Catalogs for  
Information on:  
Press Feeds  
Servo Mini Press**

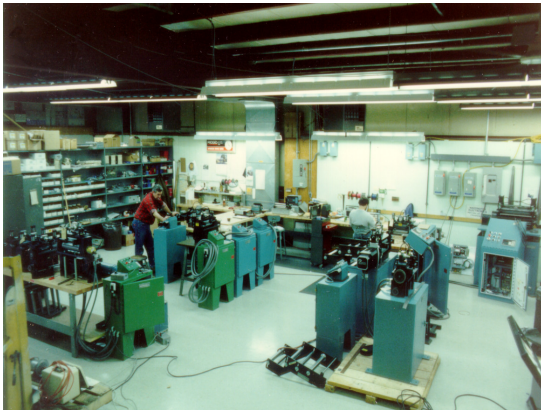

**Control Panels  
Loop Controls  
Dyna-Stop  
E-Z Circuits**



**Press Controls  
Die Protection  
Tonnage Monitoring  
Cam Switches**

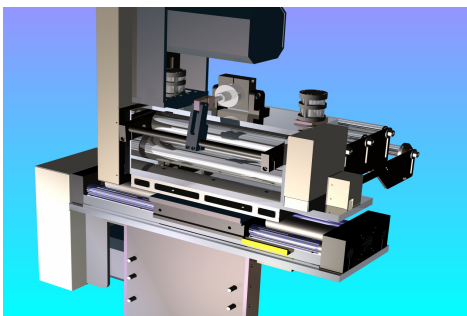

**Zig-Zag feeds  
Pull Rolls  
Custom Machines**



---

## **Waddington Electronics Inc.**

25 Webb St  
Cranston RI USA  
02920

Phone: 401-781-3904  
Fax: 401-781-1650  
Email: [sales@waddingtonelectronics.com](mailto:sales@waddingtonelectronics.com)